

1 Box Contents

A. The box contains the following items:

- Pool unit
- Home unit
- Docking Station and Plastic Cover
- Power Cord
- Accessories Pack
- Quick Start Guide

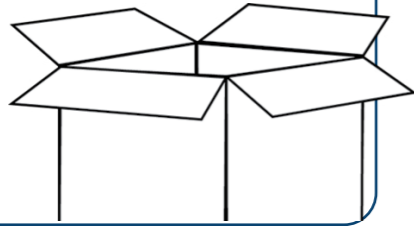

2 Power Up

A. Connect the power cord to the pool unit and plug the other end into a power outlet.

B. The device blinks white, and after a minute changes to purple.

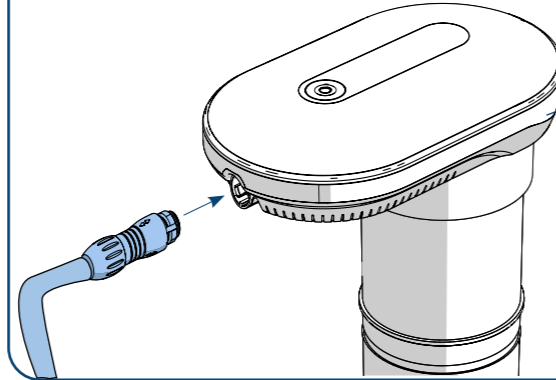
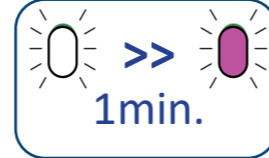

Note: The device should not be operated out of water more than 10 minutes.

3 Mobile App Installation

A. Download and launch the MYLO by Coral Smart Pool mobile application.



B. Follow the app installation wizard. When instructed, scan the device QR code:

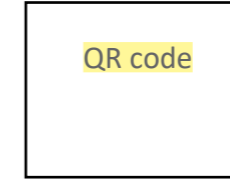

C. After pairing the app to the device and accepting the terms, the device lights will turn to green, indicating it is now active



D. Disconnect the device from power.

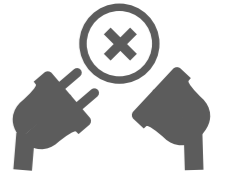

Note: Please be aware that the initial installation of the app designates the user as the MYLO administrator.

Note: The system will NOT work until you pair it with your phone and accept the terms.

4 MYLO Location Selection

A. Select the MYLO mounting location. See system requirements in the MYLO website for pool size, shape and dimensions. The docker can be mounted in either of the following methods:

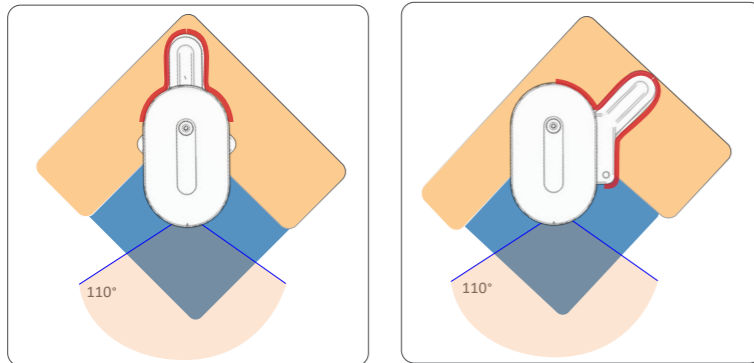

Before drilling and connecting the docking station, check that the selected location and orientation provides MYLO with the best possible coverage of the pool by following B-D below:

B. Plug the MYLO unit into a power outlet near the pool. It will flash white for about a minute, then green.

C. Hold MYLO carefully in the chosen position to prevent it from falling into the water. Ask someone to refresh the image on the application and make sure the entire pool floor is visible. Adjust the position if needed.

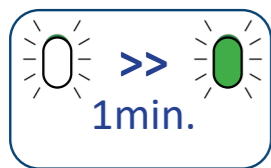

D. Take MYLO out of the water and disconnect the device from power.

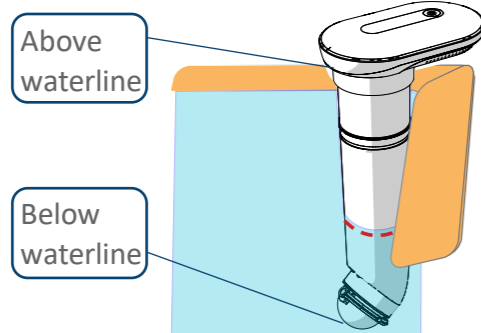

5 Docker Mounting and MYLO Installation

A. Verify that the vertical metal part of the docking station touches the inner wall of the pool.

B. Mark the location of the screws.

C. Drill two 8mm (5/16") holes.

D. Mount the docking station using screws and anchors found in the accessories pack, then attach the base plate cover.

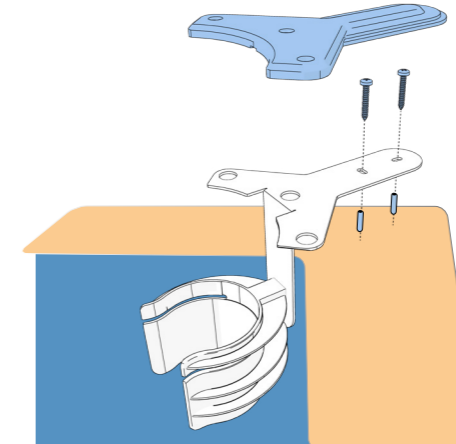
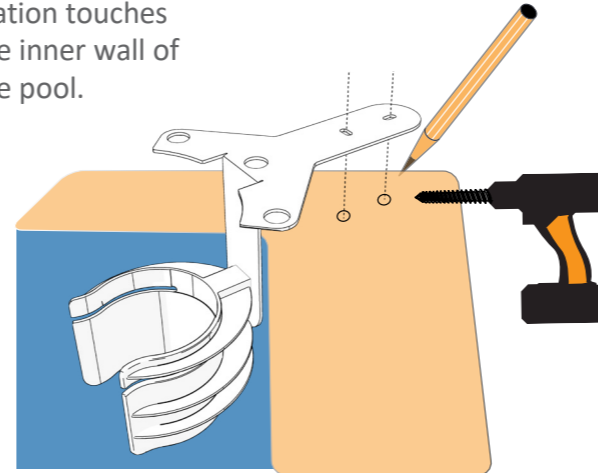

E. Insert MYLO into the docking station.

F. The mark on the tube must be at or below the waterline.

G. Insert the pool unit pin in a straight or a rotated docking position and connect to power.

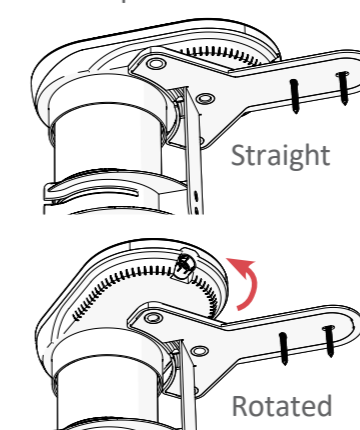
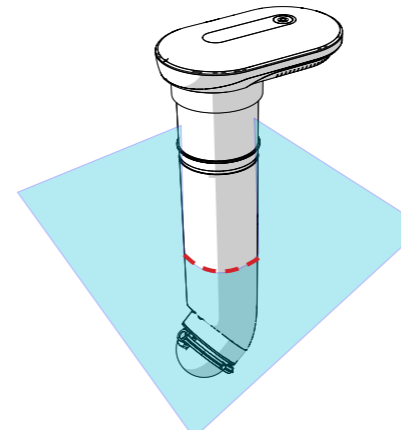
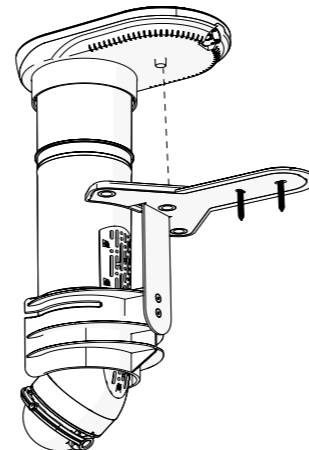

6 Home Unit Connection

A. Plug the home unit into the indoor power outlet that is closest to the pool unit, with a maximum distance of 100ft/30m.

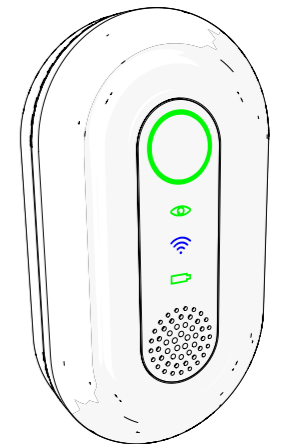

Disclaimers:

Using MYLO is subject to the acceptance of the "Terms of Use" and "Privacy Policy". | Setting up and installing MYLO indicates your acceptance of the "Terms of Use" and "Privacy Policy". | If you do NOT accept the "Terms of Use" and "Privacy Policy" please contact us to arrange a refund and return shipment. | Activating MYLO requires pairing it with a smartphone using the MYLO App (using the app is mandatory only for activating the system).



Important Safety Instructions

- MYLO does not replace adult supervision.
- MYLO serves as an additional safety measure, and is not a substitute for other pool safety devices, or compliance with local laws.
- MYLO uses computer vision technology to detect drowning. Depending on various factors, some drowning events might not be detected.
- MYLO uses Wi-Fi to transfer alerts, warnings, notifications, and images from the pool unit to your paired devices using secured cloud servers.
- Communication to paired devices depends on the quality of the home Wi-Fi network, and could, on occasion, be degraded or slower depending on signal quality.
- The Drowning Detection function operates independently of Wi-Fi communication. Alarms and indicators on both the pool unit and home unit do not rely on Wi-Fi network quality.
- Ensure that the home unit is plugged into a power outlet inside the house positioned as close as possible to the pool unit with maximum distance of 100 ft /30 meters. It is important that the home unit remains visible and audible within the house at all times.
- Extended above-water operation of the system (for over 10 minutes), or a water-level below the minimum mark can result in processor damage as the system relies on water for cooling. Please note that such damage is not covered by the warranty.
- During nighttime, MYLO can utilize its high-resolution cameras if pool lights or outdoor lights are on. In complete darkness, MYLO will be unable to monitor pool activity and detect drowning.
- **ADULT SUPERVISION IS REQUIRED AT ALL TIMES.**

Controls and Indicators

Indicators

1	Pool Activity Indicator
2	Water Visibility Indicator
3	Communication Indicator
4	Power Indicator
5	Alarm Dismiss Button
6	Buzzer

Handling False Alarms

7	Not a person button Tap to silence the alarm and teach the system to further ignore similar scenarios in the future.
8	Silent Button
9	Refresh Button

Screen Overview

10	Menu Button
11	Status Messages



Alert Scenarios

Approaching the pool

MYLO emits a single beep alert when it detects someone approaching the pool whenever the pool area has not been occupied for at least 5 minutes.

The pool activity indicators will blink green rapidly.

Note:
When there are no people in or around the pool, the pool activity indicators blink green slowly.



Entering the Pool

MYLO emits a single beep* alert when someone enters the pool whenever the pool has not been occupied for at least 5 minutes.

*In the app settings, you can opt for a short siren instead of a beep.

The pool activity indicators will blink green rapidly.



Drowning Suspicion

MYLO activates a continuous loud siren upon detecting a motionless body underwater for a duration of 12 to 20 seconds.

The pool activity indicators will blink RED rapidly.

- For any inquiry contact us at support@coraldd.com
- For the full user manual, visit our website www.coralmylo.com.